

Contents

HP E2273A, E2274A User's and SCPI Programming Manual

Edition 1

Warranty	3
Safety Symbols	4
WARNINGS	4
WARNINGS	5
Declaration of Conformity	6
Reader Comment Sheet	7
Chapter 1	
Configuring the Modules	9
What's in this Manual?	9
Module Descriptions	10
General Features	10
HP E2273A Description	10
HP E2274A Description	10
Wiring and Configuration	11
Identifying M-Modules	11
Assembling the Field Wiring Connector	12
HP E2273A 8-Ch. Form C Switch Wiring Information	13
HP E2274A 4-Ch. Form C Power Relay Wiring Information	14
Chapter 2	
SCPI Programming	15
Using This Chapter	15
Example 1: Initial Operation	15
Closing and Opening Channels	17
Channel Lists	17
Example 2: Closing Multiple Channels	18
Chapter 3	
SCPI Command Reference	21
DIAGnostic	24
DIAGnostic:INTerrupt[:LINE] <number>	24
DIAGnostic:INTerrupt[:LINE]?	24
DIAGnostic:TEST?	25
DISPlay	26
DISPLay:MONitor[:STATe]	26
DISPLay:MONitor[:STATe]?	26
[ROUTE:]	27
CLOSE	27
CLOSE?	28
OPEN	29
OPEN?	30

STATus.....	31
STATus:OPERation:CONDition?	33
STATus:OPERation:ENABLE	33
STATus:OPERation:ENABLE?	33
STATus:OPERation[:EVENT]?	34
STATus:PRESet	34
SYSTEM.....	35
SYSTEM:ERRor?	35
SYSTEM:VERSion?	35
SCPI Command Quick Reference	36
IEEE 488.2 Common Command Reference	37
Chapter 4	
Register Descriptions	39
About This Chapter.....	39
Register Addressing.....	39
A16 Address Base	39
A16 Addressing	41
A24 Addressing	41
Program Example	43
Register Descriptions.....	45
Registers in A16 Address Space	45
Registers in A24 Address Space	47
Appendix A	
Specifications	51
M-Module Specification Compliance.....	51
HP E2273A 8-Channel Form C Switch M-Module Specifications	51
HP E2274A 4-Channel Form C Power Relay M-Module Specifications	53
Index	55

Certification

Hewlett-Packard Company certifies that this product met its published specifications at the time of shipment from the factory. Hewlett-Packard further certifies that its calibration measurements are traceable to the United States National Institute of Standards and Technology (formerly National Bureau of Standards), to the extent allowed by that organization's calibration facility, and to the calibration facilities of other International Standards Organization members.

Warranty

This Hewlett-Packard product is warranted against defects in materials and workmanship for a period of three years from date of shipment. Duration and conditions of warranty for this product may be superseded when the product is integrated into (becomes a part of) other HP products. During the warranty period, Hewlett-Packard Company will, at its option, either repair or replace products which prove to be defective.

For warranty service or repair, this product must be returned to a service facility designated by Hewlett-Packard (HP). Buyer shall prepay shipping charges to HP and HP shall pay shipping charges to return the product to Buyer. However, Buyer shall pay all shipping charges, duties, and taxes for products returned to HP from another country.

HP warrants that its software and firmware designated by HP for use with a product will execute its programming instructions when properly installed on that product. HP does not warrant that the operation of the product, or software, or firmware will be uninterrupted or error free.

Limitation Of Warranty

The foregoing warranty shall not apply to defects resulting from improper or inadequate maintenance by Buyer, Buyer-supplied products or interfacing, unauthorized modification or misuse, operation outside of the environmental specifications for the product, or improper site preparation or maintenance.

The design and implementation of any circuit on this product is the sole responsibility of the Buyer. HP does not warrant the Buyer's circuitry or malfunctions of HP products that result from the Buyer's circuitry. In addition, HP does not warrant any damage that occurs as a result of the Buyer's circuit or any defects that result from Buyer-supplied products.

NO OTHER WARRANTY IS EXPRESSED OR IMPLIED. HP SPECIFICALLY DISCLAIMS THE IMPLIED WARRANTIES OF MERCHANTABILITY AND FITNESS FOR A PARTICULAR PURPOSE.

Exclusive Remedies

THE REMEDIES PROVIDED HEREIN ARE BUYER'S SOLE AND EXCLUSIVE REMEDIES. HP SHALL NOT BE LIABLE FOR ANY DIRECT, INDIRECT, SPECIAL, INCIDENTAL, OR CONSEQUENTIAL DAMAGES, WHETHER BASED ON CONTRACT, TORT, OR ANY OTHER LEGAL THEORY.

Notice

The information contained in this document is subject to change without notice. HEWLETT-PACKARD (HP) MAKES NO WARRANTY OF ANY KIND WITH REGARD TO THIS MATERIAL, INCLUDING, BUT NOT LIMITED TO, THE IMPLIED WARRANTIES OF MERCHANTABILITY AND FITNESS FOR A PARTICULAR PURPOSE. HP shall not be liable for errors contained herein or for incidental or consequential damages in connection with the furnishing, performance or use of this material. This document contains proprietary information which is protected by copyright. All rights are reserved. No part of this document may be photocopied, reproduced, or translated to another language without the prior written consent of Hewlett-Packard Company. HP assumes no responsibility for the use or reliability of its software on equipment that is not furnished by HP.

U.S. Government Restricted Rights

The Software and Documentation have been developed entirely at private expense. They are delivered and licensed as "commercial computer software" as defined in DFARS 252.227-7013 (Oct 1988), DFARS 252.211-7015 (May 1991) or DFARS 252.227-7014 (Jun 1995), as a "commercial item" as defined in FAR 2.101(a), or as "Restricted computer software" as defined in FAR 52.227-19 (Jun 1987)(or any equivalent agency regulation or contract clause), whichever is applicable. You have only those rights provided for such Software and Documentation by the applicable FAR or DFARS clause or the HP standard software agreement for the product involved.



HP E2273A/E2274A M-Modules User's Manual and SCPI Programming Guide
Edition 1

Copyright © 1997 Hewlett-Packard Company. All Rights Reserved.

Documentation History

All Editions and Updates of this manual and their creation date are listed below. The first Edition of the manual is Edition 1. The Edition number increments by 1 whenever the manual is revised. Updates, which are issued between Editions, contain replacement pages to correct or add additional information to the current Edition of the manual. Whenever a new Edition is created, it will contain all of the Update information for the previous Edition. Each new Edition or Update also includes a revised copy of this documentation history page.

Edition 1 June 1997

Safety Symbols



Instruction manual symbol affixed to product. Indicates that the user must refer to the manual for specific WARNING or CAUTION information to avoid personal injury or damage to the product.



Indicates the field wiring terminal that must be connected to earth ground before operating the equipment. Protects against electrical shock in case of fault.

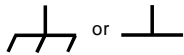

Frame or chassis ground terminal—typically connects to the equipment's metal frame.



Alternating current (AC)



Direct current (DC).



Indicates hazardous voltages.

WARNING

Calls attention to a procedure, practice, or condition that could cause bodily injury or death.

CAUTION

Calls attention to a procedure, practice, or condition that could possibly cause damage to equipment or permanent loss of data.

WARNINGS

The following general safety precautions must be observed during all phases of operation, service, and repair of this product. Failure to comply with these precautions or with specific warnings elsewhere in this manual violates safety standards of design, manufacture, and intended use of the product. Hewlett-Packard Company assumes no liability for the customer's failure to comply with these requirements.

Ground the equipment: For Safety Class 1 equipment (equipment having a protective earth terminal), an uninterruptible safety earth ground must be provided from the mains power source to the product input wiring terminals or supplied power cable.

DO NOT operate the product in an explosive atmosphere or in the presence of flammable gases or fumes.

For continued protection against fire, replace the line fuse(s) only with fuse(s) of the same voltage and current rating and type. DO NOT use repaired fuses or short-circuited fuse holders.

Keep away from live circuits: Operating personnel must not remove equipment covers or shields. Procedures involving the removal of covers or shields are for use by service-trained personnel only. Under certain conditions, dangerous voltages may exist even with the equipment switched off. To avoid dangerous electrical shock, DO NOT perform procedures involving cover or shield removal unless you are qualified to do so.

DO NOT operate damaged equipment: Whenever it is possible that the safety protection features built into this product have been impaired, either through physical damage, excessive moisture, or any other reason, REMOVE POWER and do not use the product until safe operation can be verified by service-trained personnel. If necessary, return the product to a Hewlett-Packard Sales and Service Office for service and repair to ensure that safety features are maintained.

DO NOT service or adjust alone: Do not attempt internal service or adjustment unless another person, capable of rendering first aid and resuscitation, is present.

DO NOT substitute parts or modify equipment: Because of the danger of introducing additional hazards, do not install substitute parts or perform any unauthorized modification to the product. Return the product to a Hewlett-Packard Sales and Service Office for service and repair to ensure that safety features are maintained.

WARNINGS

In a cleanroom environment (see Specifications, Appendix A) the HP E2273A and E2274A are capable of switching voltages that could cause bodily injury or death to an operator. Special precautions must be adhered to (discussed below) when applying voltages in excess of 60 Vdc, 30 Vac rms or 42.4 Vac peak for a continuous, complex waveform.

Module connectors, and test signal cables connected to them, must be made NON-accessible to an operator who has not been told to access them: It is a supervisor's responsibility to advise an operator that dangerous voltages exist when the operator is instructed to access connectors and cables carrying these voltages. Making cables and connectors that carry hazardous voltages inaccessible is a protective measure keeping an operator from inadvertent or unknowing contact with these harmful voltages. Cables and connectors are considered inaccessible if a tool (e.g., screwdriver, wrench, socket, etc.) or a key (equipment in a locked cabinet) is required to gain access to them. Additionally, the operator cannot have access to a conductive surface connected to any cable conductor (High, Low or Guard).

Assure the equipment under test has adequate insulation between the cable connections and any operator-accessible parts (doors, covers, panels, shields, cases, cabinets, etc.): Verify there are multiple and sufficient protective means (rated for the voltages you are applying) to assure the operator will NOT come into contact with any energized conductor even if one of the protective means fails to work as intended. For example, the inner side of a case, cabinet, door, cover or panel can be covered with an insulating material as well as routing the test cables to the module's front panel connectors through non-conductive, flexible conduit such as that used in electrical power distribution.

Declaration of Conformity
according to ISO/IEC Guide 22 and EN 45014

Manufacturer's Name: Hewlett-Packard Company
Loveland Manufacturing Center

Manufacturer's Name: Hewlett-Packard Company
Loveland Manufacturing Center

declares, that the product:

Product Name: 8-Channel Form C Switch M-Module, 4-Channel Form C Power Relay M-Module

Model Number: HP E2273A and HP E2274A

Product Options: All

conforms to the following Product Specifications:

Safety: IEC 1010-1 (1990) Incl. Amend 2 (1996)/EN61010-1 (1993)
CSA C22.2 #1010.1 (1992)
UL 3111-1 (1994)

EMC: CISPR 11:1990/EN55011 (1991): Group1, Class A
EN61000-3-2:1995 Class A
EN50082-1:1992
IEC 801-2:1991: 4kVCD, 8kVAD
IEC 801-3:1984: 3 V/m
IEC 801-4:1988: 1kV Power Line, 0.5kV Signal Lines
ENV50141:1993/prEN50082-1 (1995): 3 Vrms
ENV50142:1994/prEN50082-1 (1995): 1 kV CM, 0.5 kV DM
IEC1000-4-8:1993/prEN50082-1 (1995): 3 A/m
EN61000-4-11:1994/prEN50082-1 (1995): 30%, 10ms 60%, 100ms

Supplementary Information: The product herewith complies with the requirements of the Low Voltage Directive 73/23/EEC and the EMC Directive 89/336/EEC (inclusive 93/68/EEC) and carries the "CE" mark accordingly.

Tested in a typical configuration in an HP C-Size VXI mainframe.

April 7, 1997



Jim White, QA Manager

European contact: Your local Hewlett-Packard Sales and Service Office or Hewlett-Packard GmbH, Department HQ-TRE, Herrenberger Straße 130, D-71034 Böblingen, Germany (FAX +49-7031-14-3143)

Please fold and tape for mailing

Reader Comment Sheet

HP E2273A/E2274 Relay M-Module User's Manual & SCPI Programming Guide

Edition 1

You can help us improve our manuals by sharing your comments and suggestions. **In appreciation of your time, we will enter you in a quarterly drawing for a Hewlett-Packard Palmtop Personal Computer** (U.S. government employees are not eligible for the drawing).

_____ Your Name	_____ City, State/Province
_____ Company Name	_____ Country
_____ Job Title	_____ Zip/Postal Code
_____ Address	_____ Telephone Number with Area Code

Please list the system controller, operating system, programming language, and plug-in modules you are using.

fold here

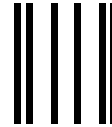

**NO POSTAGE
NECESSARY
IF MAILED
IN THE
UNITED STATES**

BUSINESS REPLY MAIL
FIRST CLASS PERMIT NO. 37 LOVELAND, CO

POSTAGE WILL BE PAID BY ADDRESSEE

HEWLETT-PACKARD COMPANY

Measurement Systems Division
Learning Products Department
P.O. Box 301
Loveland, CO 80539-9984

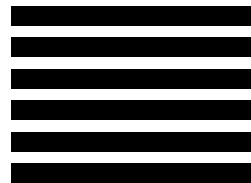

cut along this line



fold here

Please pencil-in one circle for each statement below:

- The documentation is well organized.
- Instructions are easy to understand.
- The documentation is clearly written.
- Examples are clear and useful.
- Illustrations are clear and helpful.
- The documentation meets my overall expectations.

Disagree ←————→ Agree

<input type="radio"/>	<input type="radio"/>	<input type="radio"/>	<input type="radio"/>	<input type="radio"/>
<input type="radio"/>	<input type="radio"/>	<input type="radio"/>	<input type="radio"/>	<input type="radio"/>
<input type="radio"/>	<input type="radio"/>	<input type="radio"/>	<input type="radio"/>	<input type="radio"/>
<input type="radio"/>	<input type="radio"/>	<input type="radio"/>	<input type="radio"/>	<input type="radio"/>
<input type="radio"/>	<input type="radio"/>	<input type="radio"/>	<input type="radio"/>	<input type="radio"/>
<input type="radio"/>	<input type="radio"/>	<input type="radio"/>	<input type="radio"/>	<input type="radio"/>

Please write any comments or suggestions below—be specific.

Chapter 1

Configuring the Modules

What's in this Manual?

This manual contains general information, block diagram descriptions, configuration and wiring information, SCPI programming information, register maps, and specifications for these M-Modules:

- HP E2273A 8-Channel Form C Switch
- HP E2274A 4-Channel Form C Power Relay

The contents of this chapter are:

- Module Descriptions Page 10
- Wiring and Configuration Page 11
- HP E2273A 8-Ch. Form C Switch Wiring Information Page 13
- HP E2274A 4-Ch. Form C Power Relay Wiring Information Page 14

Module Descriptions

General Features

- Simple CLOSE and OPEN commands to operate switches provide for easy operation.
- Single-width M-Modules provide high density and maximum flexibility of configuration.
- Low cost switching in VXI environment.
- General Purpose Relays provide the way to activate external devices with a single switch closure.

HP E2273A Description

HP E2273A 8-Channel Form C Switch is a single-wide, register-based M-Module. It provides 8 individual Form C (SPDT) channels for general purpose switching and control of external devices. Using an external power supply, you can use this module to drive programmable attenuators and microwave switches. The simplified switching schematic and user connector diagram are shown in Figure 1-2. on Page 13.

HP E2274A Description

HP E2274A 4-Channel Form C Power Relay is a single-wide, register-based M-Module. It provides 4 individual Form C (SPDT) channels for general purpose switching and control of external devices. With its 5 ADC per channel current rating, it can be used to switch external power supplies. The simplified switching schematic and user connector diagram are shown in Figure 1-3. on Page 14.

Wiring and Configuration

This section describes how to connect user wiring to the HP E2273A and E2274A M-Modules.

Note The procedures in this section assume the M-Module(s) have already been installed into an M-Module Carrier such as the HP E2251. Since installation is dependent on the carrier used, instructions for installing M-Modules into the carrier are not included here. Refer to your M-Module carrier documentation for installation instructions.

WARNING **SHOCK HAZARD. Only service-trained personnel aware of the hazards involved should install, configure, or remove the modules. Disconnect all power sources from the mainframe, the terminal module(s) and the installed modules before installing or removing a module.**

Caution **STATIC ELECTRICITY. Static electricity is a major cause of component failure. To prevent damage to the electrical components on an M-Module or the carrier, observe anti-static techniques whenever installing, removing, or working on a carrier or M-Module.**

Identifying M-Modules

Hewlett-Packard M-Modules have a module ID number on the back of the PC-board. The ID number consists of a model number prefix and a PC-board number suffix. For example, "E2273-66501" is the ID number for the HP E2273 M-Module. The locations of these numbers are shown in Figures 1-2 and 1-3.

Assembling the Field Wiring Connector

Each M-Module includes a 44-pin connector and hood (HP kit part number E2273-01203). You must supply your own cable. The figure below shows how to connect wiring and assemble the connector and hood.

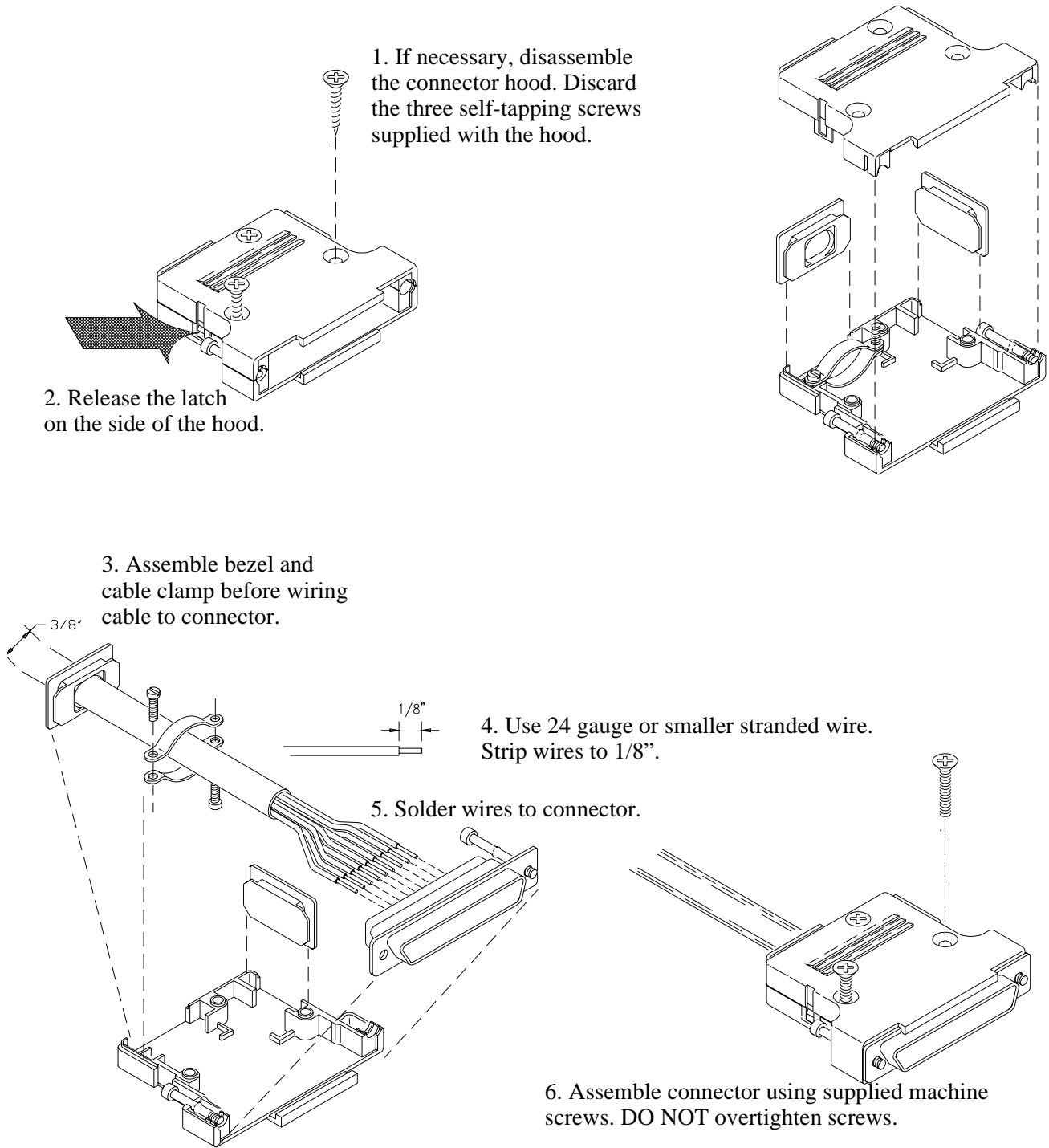
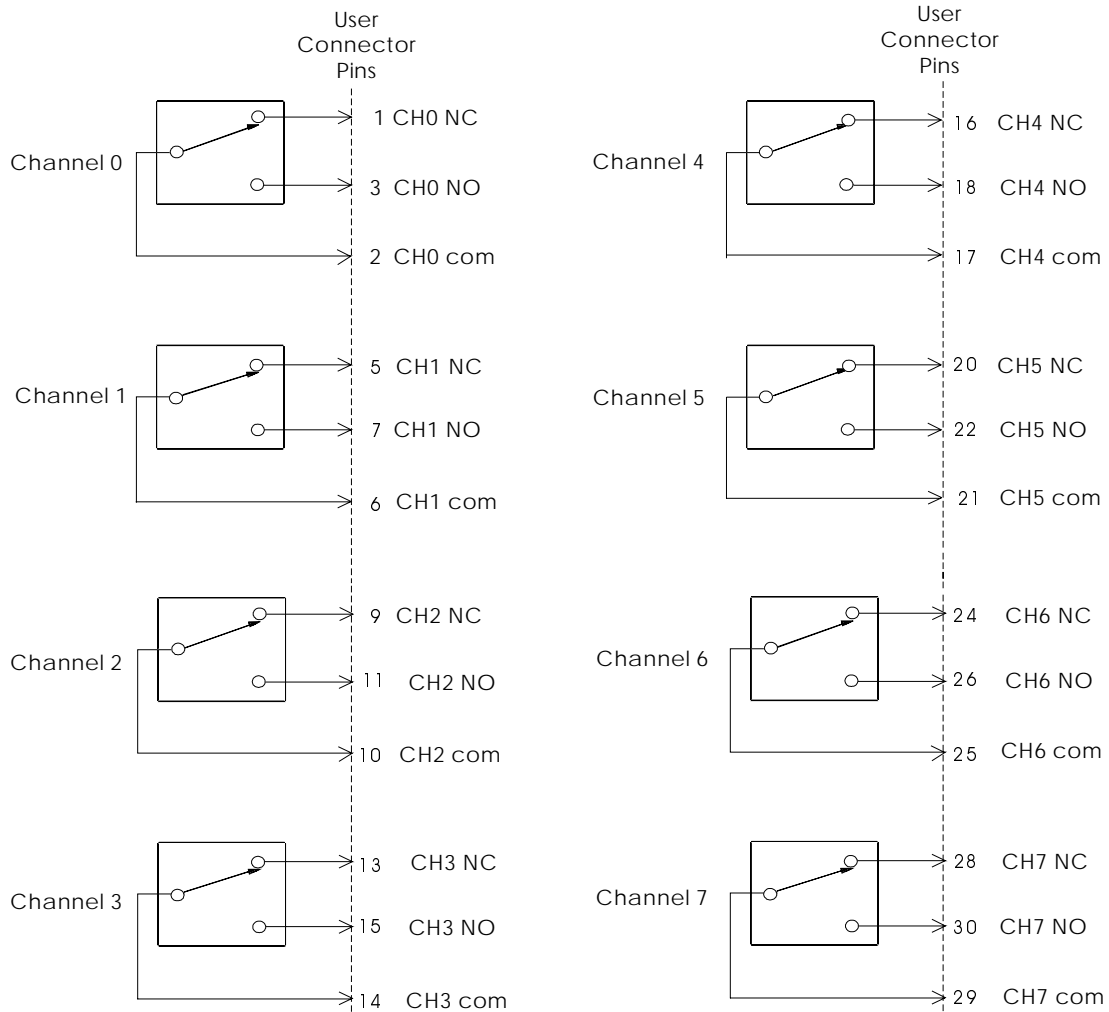
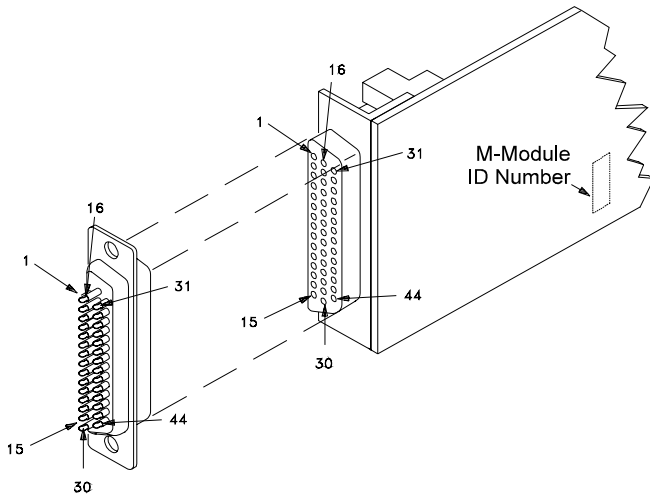

Figure 1-1. Assembling the Field Wiring Connector

HP E2273A 8-Ch. Form C Switch Wiring Information



NC = Normally Closed
 NO = Normally Open
 com = Common

CGND: Pin 4, 8, 12, 19, 23, 31-44

Figure 1-2. Simplified E2273A Switch Schematic and User Connector

HP E2274A 4-Ch. Form C Power Relay Wiring Information

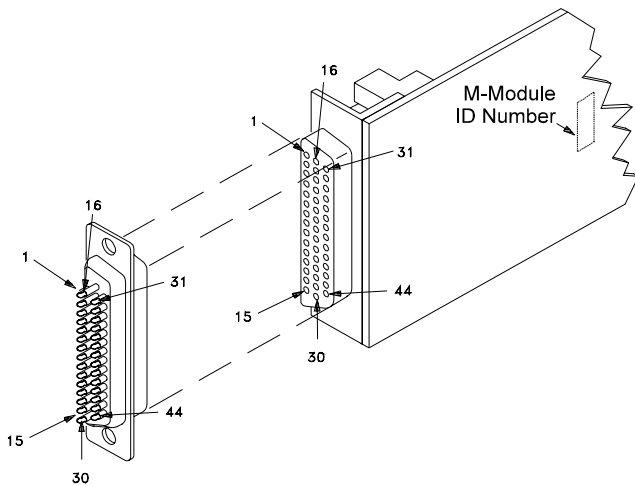

MAXIMUM VOLTAGE/CURRENT: The maximum voltage that may be applied to any connector on the HP E2274A is 125 VDC, 141 VAC rms, or 200 VAC peak. These limits apply only if the product is installed in a humidity-controlled (<60% RH) environment where airborne contaminants and transients are controlled, and there is NOT a relay connection made to power mains. If these conditions CANNOT be maintained, then the maximum voltage is 60 VDC, 43 VAC rms or 68 VAC peak.

The maximum current (non-inductive) that may be applied to the HP E2274A is 5 ADC, 5 AAC peak per switch. Maximum power is 100 WDC, 100 VA AC, per switch; 300 WDC, 300 VA AC per M-module.

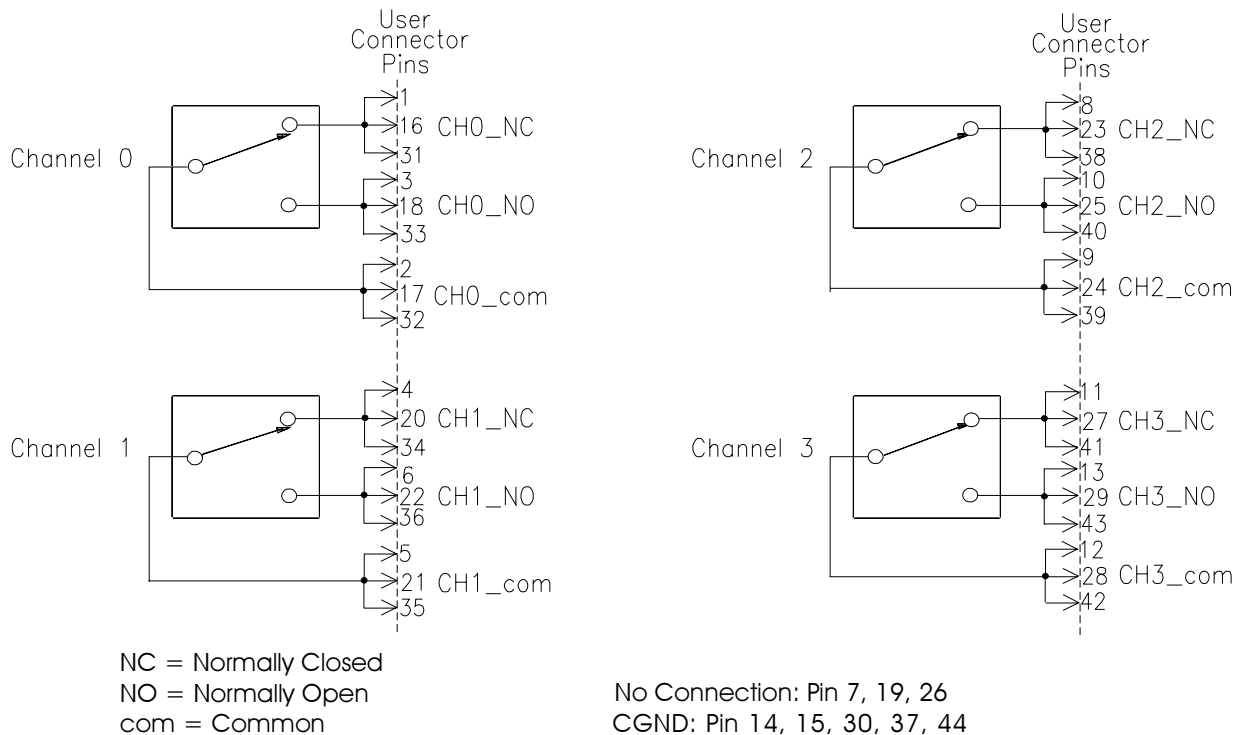

Figure 1-3. Simplified E2274A Power Switching Schematic and User Connector

Caution All three pins of each relay contact must be connected together in the field wiring for maximum current capability. For example, for Channel 0, pins 1, 16, and 31 (for NC contacts must be wired together in the field wiring, likewise pins 3, 18, and 33 (for the NO contact) and pins 2, 17, and 32 for channel common.

Chapter 2

SCPI Programming

Using This Chapter

This chapter contains SCPI program examples that demonstrate how to read a module ID, perform self-test, and open and close channels. The program examples are written in C language and can be used on either the HP E2273 or the E2274. To run one of these programs you must have the HP SICL Library, the HP VISA Library, an HP-IB interface module installed in an external PC, an HP E1406 Command Module, and an HP E2273 or E2274 M-Module installed on the HP E2251 Carrier.

Example1: Initial Operation

The following example reads the module ID string, performs module self-test, and displays the results.

```
#include <visa.h>
#include <stdio.h>
#include <stdlib.h>

    /* Interface address is 9, M-Module secondary address is 3 */
#define INSTR_ADDR "GPIB0::9::3::INSTR"

int main()
{
    ViStatus errStatus;           /*Status from each VISA call*/
    ViSession viRM;              /*Resource mgr. session */
    ViSession m_mod;            /* M-module session */
    char id_string[256];         /*ID string*/
    char selftst_string[256];    /*self-test string*/

    /* Open the default resource manager */
    errStatus = viOpenDefaultRM ( &viRM);
    if(VI_SUCCESS > errStatus){
        printf("ERROR: viOpenDefaultRM() returned 0x%x\n",errStatus);
        return errStatus;}

    /* Open the M-Module instrument session */
    errStatus = viOpen(viRM,INSTR_ADDR, VI_NULL,VI_NULL,&m_mod);
    if(VI_SUCCESS > errStatus){
        printf("ERROR: viOpen() returned 0x%x\n",errStatus);
        return errStatus;}
```

(program continued on next page)

```

    /* Reset the M-Module */
errStatus = viPrintf(m_mod, "**RST\n");
if(VI_SUCCESS > errStatus){
    printf("ERROR: viPrintf() returned 0x%x\n",errStatus);
    return errStatus;}

    /* Perform M-Module Self-Test */
errStatus = viQueryf(m_mod,"*TST?\n","%t",selfst_string);
if (VI_SUCCESS > errStatus) {
    printf("ERROR: viPrintf() returned 0x%x\n",errStatus);
    return errStatus;}
printf("Self Test Result is %s\n",selfst_string);

    /* Query the M-Module ID string */
errStatus = viQueryf(m_mod,"*IDN?\n","%t",id_string);
if (VI_SUCCESS > errStatus) {
    printf("ERROR: viPrintf() returned 0x%x\n",errStatus);
    return errStatus;}
printf("ID is %s\n",id_string);

    /* Close the M_Module Instrument Session */
errStatus = viClose (m_mod);
if (VI_SUCCESS > errStatus) {
    printf("ERROR: viClose() returned 0x%x\n",errStatus);
    return 0;}

    /* Close the Resource Manager Session */
errStatus = viClose (viRM);
if (VI_SUCCESS > errStatus) {
    printf("ERROR: viClose() returned 0x%x\n",errStatus);
    return 0;}

return VI_SUCCESS;
}

```

Closing and Opening Channels

The [ROUte]:CLOSe<*channel_list*> command closes one or more channels on a Switch M-Module. The [ROUte]:OPEN<*channel_list*> opens one or more channels.

Note The [ROUte]: portion of the command is optional syntax and can be omitted. For example, the command [ROUte]:CLOSE <*channel list*> can be shortened to CLOSE <*channel list*>.

Channel Lists

The <*channel list*> parameter in the CLOSE or OPEN command has the form (@*ccnn*), where *cc* is the card number and *nn* is the channel number.

Note The SCPI Driver supports single modules only, therefore *cc* is always 1. To simplify programming, the card number (*cc*) can be eliminated. The remainder of this manual will use the shortened (no card number) channel list format (@*nn*).

You can specify a single channel (@*nn*), use commas to specify multiple channels (@*nn,nn,...*), or use a colon to specify a range of channels (@*nn:nn*). You can also specify any combination of single channels, multiple channels, and channel ranges. Some examples:

```
CLOS (@00,03)
    !Close channels 00 and 03
```

```
OPEN (@01,02,03,07)
    ! Open channels 01, 02, 03 and 07
```

```
OPEN (@00:07)
    ! Open channels 00 through 07
```

```
CLOS (@02:04,07)
    ! Close channels 02 through 04 and 07
```

Note A range of channels (@*nn:nn*) must be specified in ascending order, that is lower channel number on the left, higher number on the right.

Switch M-Module Channel Numbers

- The HP E2273's channels are numbered 00 through 07.
- The HP E2274's channels are numbered 00 through 03.

Example 2: Closing Multiple Channels

The following example closes channel 00 and channels 02 through 03 on a Switch M-Module. The program then opens channels 00 and 03. The program assumes an M-Module secondary address of 3 and an interface address of 9.

```
#include <visa.h>
#include <stdio.h>
#include <stdlib.h>
    /* Interface address is 9, M-Module secondary address is 3*/
#define INSTR_ADDR "GPIB0::9::3::INSTR"

int main()
{
    ViStatus errStatus;                /*Status from each VISA call*/
    ViSession viRM;                    /*Resource mgr. session */
    ViSession m_mod;                   /* M-module session */

    /* Open the default resource manager */
    errStatus = viOpenDefaultRM ( &viRM);
    if(VI_SUCCESS > errStatus){
        printf("ERROR: viOpenDefaultRM() returned 0x%x\n",errStatus);
        return errStatus;}

    /* Open the M-Module instrument session */
    errStatus = viOpen(viRM,INSTR_ADDR, VI_NULL,VI_NULL,&m_mod);
    if(VI_SUCCESS > errStatus){
        printf("ERROR: viOpen() returned 0x%x\n",errStatus);
        return errStatus;}

    /* Reset the M-Module */
    errStatus = viPrintf(m_mod, "**RST\n");
    if(VI_SUCCESS > errStatus){
        printf("ERROR: viPrintf() returned 0x%x\n",errStatus);
        return errStatus;}

    /* Close channels 1 through 3 on the M-Module */
    errStatus = viPrintf(m_mod,"ROUT:CLOS (@01:03)\n");
    if (VI_SUCCESS > errStatus) {
        printf("ERROR: viPrintf() returned 0x%x\n",errStatus);
        return errStatus;}

    /* Open channel 1 on the M-Module */
    errStatus = viPrintf(m_mod,"ROUT:OPEN (@01)\n");
    if (VI_SUCCESS > errStatus) {
        printf("ERROR: viPrintf() returned 0x%x\n",errStatus);
        return errStatus;}
}
```

(program continued on next page)

```
    /* Close the M_Module Instrument Session */
errStatus = viClose (m_mod);
if (VI_SUCCESS > errStatus) {
    printf("ERROR: viClose() returned 0x%x\n",errStatus);
    return 0;}

    /* Close the Resource Manager Session */
errStatus = viClose (viRM);
if (VI_SUCCESS > errStatus) {
    printf("ERROR: viClose() returned 0x%x\n",errStatus);
    return 0;}

return VI_SUCCESS;
}
```

Chapter 3

SCPI Command Reference

Using This Chapter

This chapter describes the **Standard Commands for Programmable Instruments (SCPI)** command set and the **IEEE-488.2 Common Commands** for the HP E2273A and HP E2274A. This chapter contains the following sections:

- Command Fundamentals Page 21
- SCPI Command Reference Page 27
- Common Command Reference Page 36
- Command Quick Reference Page 37

Command Fundamentals

Commands are separated into two types: IEEE 488.2 Common commands and SCPI commands.

Common Command Format

The IEEE 488.2 standard defines the Common commands that perform functions like reset, self-test, status byte query, etc. Common commands are four or five characters in length, always begin with the asterisk character (*), and may include one or more parameters. The command keyword is separated from the first parameter by a space character. Some examples of Common commands are shown below:

```
*RST *ESR 32 *STB?
```

SCPI Command Format

The SCPI commands perform functions like closing switches, making measurements, and querying instrument states or retrieving data. A subsystem command structure is a hierarchical structure that usually consists of a top level (or root) command, one or more lower-level commands, and their parameters. The following example shows part of a typical subsystem:

```
[ROUTe:]  
  CLOSe <channel_list>
```

[ROUTe:] is the root command, CLOSe is second-level command with parameter.

Command Separator

A colon (:) always separates one command from the next lower-level command as shown below:

```
[ROUTe:] OPEN?
```

Abbreviated Commands

The command syntax shows most commands as a mixture of upper- and lowercase letters. The uppercase letters indicate the abbreviated spelling for the command. For shorter program lines, send the abbreviated form. For better program readability, you may send the entire command. The instrument will accept either the abbreviated form or the entire command.

For example, if the command syntax shows MEASure, then MEAS and MEASURE are both acceptable forms. Other forms of MEASure, such as MEASU or MEASUR will generate an error. You may use upper- or lowercase letters. Therefore, MEASURE, measure, and MeAsUrE are all acceptable.

Implied Commands

Implied commands are those which appear in square brackets ([]) in the command syntax. (*Note that the brackets are not part of the command and are not sent to the instrument.*) Suppose you send a second-level command but do not send the preceding implied command. In this case, the instrument assumes you intend to use the implied command and it responds as if you had sent it.

Examine the [ROUTe:] subsystem shown below:

```
[ROUTe:]
  CLOSe <channel_list>
  CLOSe? <channel_list>
  OPEN <channel_list>
  OPEN? <channel_list>
```

The root command [ROUTe:] is an implied command (indicated by square brackets []). To close relays in a channel list, you can send either of the following command statements:

```
[ROUTe:]CLOSe (@100:103) or CLOSe (@100:103)
```

Parameters **Parameter Types.** The following table contains explanations and examples of parameter types you might see later in this chapter.

Parameter Type	Explanations and Examples
Numeric	Accepts all commonly used decimal representations of numbers including optional signs, decimal points, and scientific notation. 123, 123E2, -123, -1.23E2, .123, 1.23E-2, 1.23000E-01. Special cases include MIN, MAX, and INF.
Boolean	Represents a single binary condition that is either true or false. ON, OFF, 1, 0.

Optional Parameters. Parameters shown within square brackets ([]) are optional parameters. (*Note that the brackets are not part of the command and are not sent to the instrument.*) If you do not specify a value for an optional parameter, the instrument chooses a default value.

Linking Commands **Linking IEEE 488.2 Common Commands with SCPI Commands.** Use a semicolon (;) between the commands. For example:

*RST;CLOS (@01) *or* OPEN (@02);*RST

Linking Multiple SCPI Commands. Use both a semicolon (;) and a colon (:) between the commands. For example:

CLOS (@02);:OPEN (@03)

DIAGnostic subsystem controls setting and querying an M-Module's interrupt line and executing the extensive self-test.

Subsystem Syntax DIAGnostic
 :INTerrupt[:LINE] <number>
 :INTerrupt[:LINE]?
 :TEST?

DIAGnostic:INTerrupt[:LINE] <number>

DIAGnostic:INTerrupt[:LINE] <number> sets M-Module interrupt level.

Parameter

Parameter Name	Parameter Type	Range of Values	Default Value
<number>	numeric	0 - 7	1

- Comments**
- Only one value (0 through 7) can be set at one time. Specifying 0 disables interrupting.
 - When enabled to interrupt, the M-Module asserts an interrupt whenever a relay close/open operation has been performed ([ROUTE] Subsystem).

Example Set the relay module's interrupt level to level 6.

DIAG:INT:LIN 6

Set the module's interrupt level to level 6.

DIAGnostic:INTerrupt[:LINE]?

DIAGnostic:INTerrupt[:LINE]? queries and returns the current interrupt level.

Example DIAG:INT[:LINE] 3

Set the interrupt level of the module to level 3.

DIAG:INT[:LINE]?

*Query the interrupt level, the returned value "3" indicates that the interrupt level is level 3.
ostic test.*

DIAGnostic:TEST?

DIAGnostic:TEST? performs an extensive relay self-test and returns a numerical and string response indicating the results of the test.

Caution The extended self-test will open and close each relay in the module. Before performing this test, make sure that external devices will not be affected by these actions. It is recommended that external devices be disconnected from the module while executing DIAGnostic:TEST?.

Returned Data

Type	Description of Numerical Response	Possible Strings Returned
int16, string	0 = self-test passed	"Self test passed"
	1 = ERROR: status register	"Busy, full bit failed. Expect 4, got X" "Busy, stuck at 0. Expect 1, got X" "Init or full bit wrong. Expect X, got X"
	2 = ERROR: register readback	"Readback reg X failed, expect 0, got X"
	3 = ERROR: interrupt	"Interrupt failed VISA error X"

Comments

- DIAG:TEST? opens all relays and then closes each relay, one at a time. It then waits for an interrupt and reads the register to verify that the relay actually closed. If an interrupt does not occur, a 3 is returned indicating a missing interrupt error. If the value that was read back does not match what was set, a 1 is returned indicating that there is a problem somewhere in the relay driver circuitry. Following the self-test, all relays are left in the open state.
- A query response of 0 means that the module is operating properly, a non-zero result means an error occurred.
- The extended self-test **does not** measure the actual relay state position to ensure that it is closed or open, it only queries the state of the Control Register circuitry. It may be possible to pass DIAGnostic:TEST? (return a 0) and still have relay failures.

Reset Condition *RST does not affect this query.

Related Commands *TST?

Example DIAG:TEST? *Perform diagnostic test.*

The DISPlay subsystem monitors the channel state of a selected module. The DISPlay command subsystem only operates with a RS-232 terminal connected to the HP E1405/1406 command module's RS-232 port. These commands control the display on the terminal, and would in most cases be typed directly from the terminal keyboard. It is possible however, to send these commands over the HP-IB interface, and control the terminal's display. In this case, care must be taken that the instrument receiving the DISPlay command is the same one that is currently selected on the terminal; otherwise, the HP-IB command will have no visible affect.

Subsystem Syntax

```
DISPlay
:MONitor
[:STATe] <mode>
[:STATe]?
```

DISPLay:MONitor[:STATe]

DISPlay:MONitor[:STATe] <mode> turns the monitor mode ON or OFF. When monitor mode is on, the RS-232 terminal display shows the opened/closed state of every switch on the module. This display is dynamically updated each time a switch is opened or closed.

Parameters

Parameter Name	Parameter Type	Range of Values	Default Value
<mode>	boolean	ON OFF 1 0	OFF 0

Comments

- **Monitoring Channels:** DISPlay:MONitor:STATe ON or DISPlay:MONitor:STATe 1 turns the monitor mode ON to show the channel state of the selected module.

DISPlay:MONitor:STATe OFF or DISPlay:MONitor:STATe 0 turns the channel monitor OFF.

- Typing in another command on the terminal will cause the DISPlay:MONitor[:STATe] to automatically be set to OFF (0).
NOTE: Use of the OFF parameter is useful only if the command is issued across the HP-IB interface.

Example

```
DISP:MON 1
```

Turn the monitor mode on.

DISPLay:MONitor[:STATe]?

DISPlay:MONitor[:STATe]? queries the monitor mode. The command returns a "1" if monitor mode is on or a "0" if monitor mode is off.

The [ROUTe] subsystem controls the closing and opening of relays.

Subsystem Syntax

```
[ROUTe:]
CLOSE <channel_list>
CLOSE? <channel_list>
OPEN <channel_list>
OPEN? <channel_list>
```

CLOSE

[ROUTe:]CLOSE <channel_list> closes the relays for the channels specified in the *channel_list*. After closing, the relay’s Common (C) terminal is connected to the Normally Open (NO) terminal.

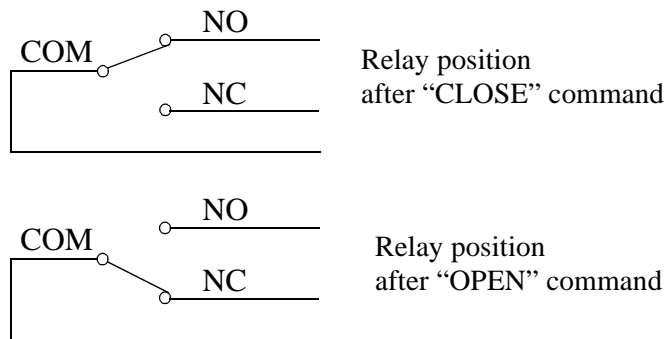

Figure 3-1. Effects of Close/Open Commands

Parameters

Parameter Name	Parameter Type	Range of Values
<channel_list>	numeric	cc00-cc07 or 00-07 E2273A cc00-cc03 or 00-03 E2274A

Comments

- The *channel_list* is in the form (@ccnn), (@ccnn,ccnn), or (@ccnn:ccnn) where:
 cc = card number (for M-Modules, cc = 1, or you can omit the card number)
 nn = channel number (00-07 for the HP E2273A) (00-03 for the HP E2274A)
- Closing Channels (card and channel syntax; ccnn):**
 To close a single channel, use [ROUTe:]CLOSE (@ccnn) or [ROUTe:]CLOSE (@nn)

 To close multiple channels, use [ROUTe:]CLOSE (@ccnn,ccnn) or [ROUTe:]CLOSE (@nn,nn)

To close sequential channels, use [ROUTE:]CLOSe (@ccnn:ccnn) or [ROUTE:]CLOSe (@nn:nn)

To close a group of sequential channels, use [ROUTE:]CLOSe (@ccnn:ccnn,ccnn:ccnn) or [ROUTE:]CLOSe (@nn:nn,nn:nn)

- **Closure Order:** A list of channels will not all close simultaneously. The order channels close when specified from a single command is not guaranteed. To ensure a particular closing order, send multiple CLOSe commands with one channel per command.
- **Related Commands:** [ROUTE:]OPEN, [ROUTE:]CLOSe?
- ***RST Condition:** All Form C switch channels are open.

Example CLOS (@100,102) or CLOS (@00,02) *Close channels 0 & 2 of the module.*

CLOSe?

[ROUTE:]CLOSe? <channel_list> returns the current state of the channel(s) queried. The *channel_list* is in the form (@ccnn). The command returns 1 if the channel is in the NO state (C connected to NO) or returns 0 if the channel is in the NC state (C connected to NC). If a list of channels is queried, a comma delineated list of 0 or 1 values is returned in the same order of the channel list.

Comments **Query is Software Readback:** The [ROUTE:]CLOSe? command returns the current state of the hardware controlling the specified channel.

Example CLOS? (@100,103) or CLOS? (@00,03) *Query the status of channels 0 & 3. If the channel is closed, the returned value is 1, otherwise the value is 0.*
CLOS? (@102) or CLOS? (@02) *Query the status of channel 2. Returned value "1" indicates the channel is closed, "0" indicates the channel is open.*

OPEN

[ROUTE:]OPEN <channel_list> opens the relays for the channels specified in the *channel_list*. After opening, the channel's Common (C) terminal is connected to the Normally Closed (NC) terminal (see "Figure 3-1. Effects of Close/Open Commands" on page 27).

Parameters

Parameter Name	Parameter Type	Range of Values
<channel_list>	numeric	cc00-cc08 or 00-07 for E2273A cc00-cc03 or 00-03 for E2274A

Comments

- The *channel_list* is in the form (@ccnn), (@ccnn,ccnn), or (@ccnn:ccnn) where:
cc = card number (for M-Modules, cc = 1, or you can omit the card number)
nn = channel number (00-07 for the HP E2273A) (00-03 for the HP E2274A)
- **Opening Channels:**
To open a single channel, use [ROUTE:]OPEN (@ccnn) or OPEN (@nn);
To open multiple channels, use [ROUTE:]OPEN (@ccnn,ccnn) or OPEN (@nn,nn);
To open sequential channels, use [ROUTE:]OPEN (@ccnn:ccnn) or OPEN (@nn:nn);
To open groups of sequential channels, use [ROUTE:]OPEN (@ccnn:ccnn,ccnn:ccnn) or OPEN (@nn:nn,nn:nn)
- **Opening Order:** A list of channels will not all open simultaneously. The order channels open when specified from a single command is not guaranteed. To ensure to particular opening order, send multiple OPEN commands with one channel per command.
- **Related Commands:** [ROUTE:]CLOSE, [ROUTE:]OPEN?
- ***RST Condition:** All Form C switch channels are open.

Example Opening Form C Switch Channels

This example opens channel 00 and 03.

OPEN (@100,103) or OPEN (@00,03) *Open the channels 0 & 3.*

OPEN?

[ROUTE:]OPEN? <channel_list> returns the current state of the channel queried. The *channel_list* is in the form (@ccnn). The command returns 1 if the channel is in the NC state (C connected to NC) or returns 0 if the channel is in the NO state (C connected to NO). If a list of channels is queried, a comma delineated list of 0 or 1 values is returned in the same order of the channel list.

- Comments**
- **Query is Software Readback:** The [ROUTE:]OPEN? command returns the current state of the hardware controlling the specified channel. It does not account for a failed switch element.

Example Query Form C Switch Channel Open State

OPEN? (@100,102) or OPEN? (@00,02) *Querying the states of channels 0 & 2. If the channel is open, the returned value is "1", otherwise the returned value is "0".*

OPEN? (@101) or OPEN? (@01) *Querying the status of channel 1. Returned value "1" indicates that the channel is open; otherwise the channel is closed.*

The STATUS subsystem reports the bit values of the Operation Status Register. It also allows you to unmask the bits you want reported from the Standard Event Register and to read the summary bits from the Status Byte Register.

Subsystem Syntax

```

STATUS
:OPERation
:CONDition?
:ENABle <unmask>
:ENABle?
[:EVENT?]
:PRESet
    
```

Each status group consists of a condition register, transition filters, event register, and enable register. The STATUS subsystem controls those commands and queries that affect the Operation status group and the QUESTIONable status group.

Syntax	Description
:STATUS	
:OPERation	
:CONDition?	Returns condition register of operation status group
:ENABle <mask>	Sets enable register of operation status group
:ENABle?	Returns enable register of operation status group
:EVENT?	Returns event register of operation status group
:PRESet	Clears operation & questionable enable registers
:QUESTionable	
:CONDition?	Returns condition register of questionable status group
:ENABle <mask>	Sets enable register of questionable status group
:ENABle?	Returns enable register of questionable status group
:EVENT?	Returns event register of questionable status group

Note The STATUS:QUESTionable commands are included in the driver for SCPI compatibility reasons only. None of the QUESTIONable bits are used by the HP E2273A or E2274A.

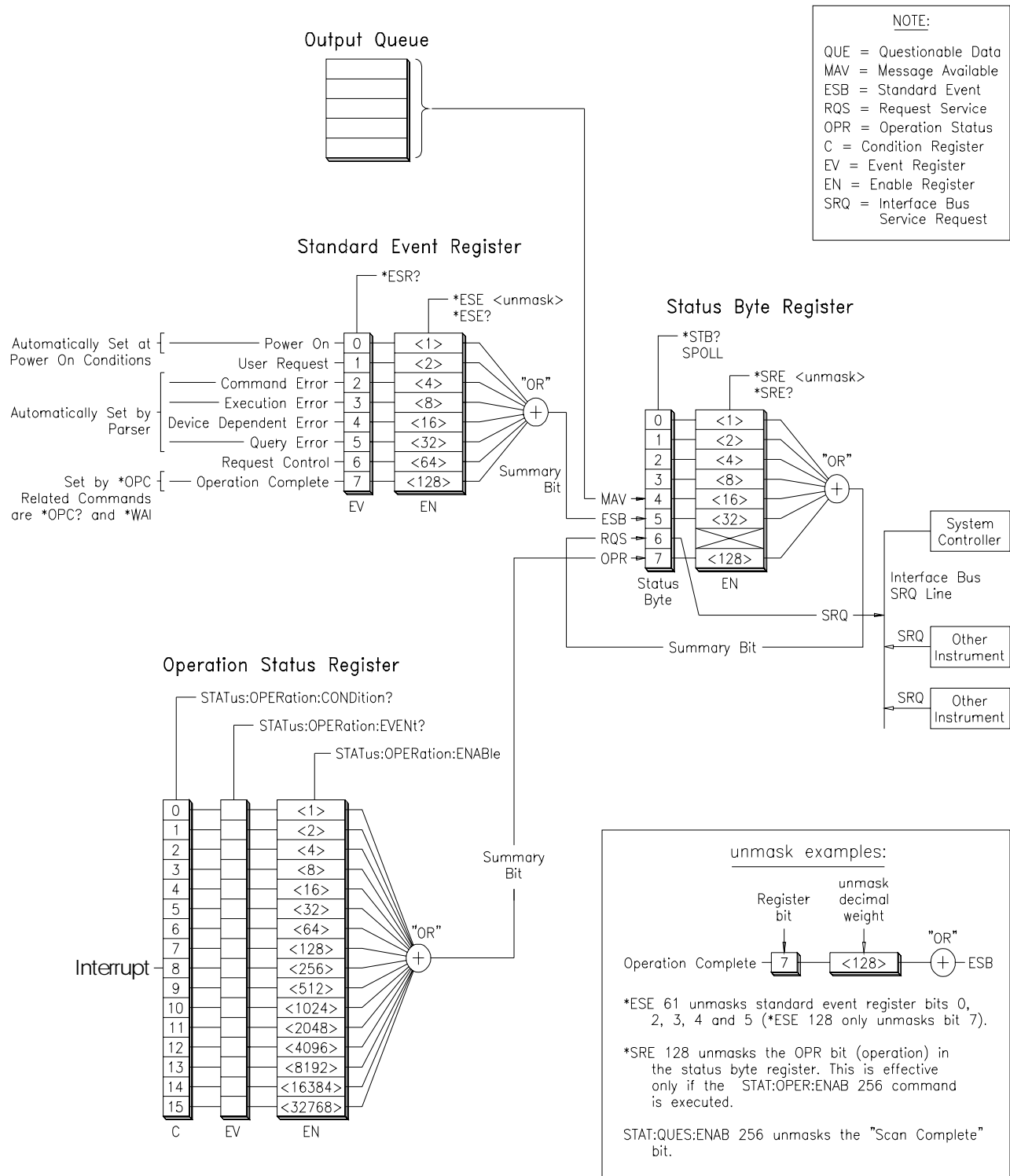

Figure 3-2. Status System

STATus:OPERation:CONDition?

STATus:OPERation:CONDition? returns the state of the Condition Register in the Operation Status Group. The state represents conditions which are part of the instrument's operation. The "SWITCH" driver does not set bit 8 in this register (see STATus:OPERation[:EVENT]?).

STATus:OPERation:ENABLE

STATus:OPERation:ENABLE <unmask> sets an enable mask to allow events recorded in the Event Register to send a summary bit to the Status Byte Register (bit 7). For Multiplexer Modules, when bit 8 in the Operation Status Register is set to 1 and that bit is enabled by the STATus:OPERation:ENABLE command, bit 7 in the Status Register is set to 1.

Parameters

Parameter Name	Parameter Type	Range of Values	Default Value
<unmask>	numeric	0 through 65,535	N/A

Comments

- **Setting Bit 7 of the Status Register:** STATus:OPERation:ENABLE 256 sets bit 7 of the Status Register to 1 after bit 8 of the Operation Status Register is set to 1.

Example

Enabling Operation Status Register Bit 8

STAT:OPER:ENAB 256

Enable bit 8 of the Operation Status Register to be reported to bit 7 (OPR) in the Status Register.

STATus:OPERation:ENABLE?

STATus:OPERation:ENABLE? returns which bits in the Event Register (Operation Status Group) are unmasked.

Comments

- **Output Format:** Returns a decimal weighted value from 0 to 65,535 indicating which bits are set to true.
- **Maximum Value Returned:** The value returned is the value set by the STAT:OPER:ENAB <unmask> command. However, the maximum decimal weighted value used in this module is 256 (bit 8 set to true).

Example

Query the Operation Status Enable Register

STAT:OPER:ENAB?

Query the Operation Status Enable Register.

STATus:OPERation[:EVENT]?

STATus:OPERation[:EVENT]? returns which bits in the Event Register (Operation Status Group) are set. The Event Register indicates when there has been a time-related instrument event.

Comments

- **Event Register Cleared:** Reading the Event Register with the **STATus:OPERation:EVENT?** command clears it.

STATus:PRESet

STATus:PRESet affects only the Enable Register by setting all Enable Register bits to 0. It does not affect either the “status byte” or the “standard event status”. **PRESet** does not clear any of the Event Registers.

The SYSTEM subsystem returns the error numbers and error messages in the error queue. It can also return a module's D-SCPI version.

Subsystem Syntax SYSTEM
 :ERRor?
 :VERSion

SYSTEM:ERRor?

SYSTEM:ERRor? returns the error numbers and corresponding error messages in the error queue.

Comments

- **Error Numbers/Messages in the Error Queue:** Each error generated stores an error number and corresponding error message in the error queue. The error message can be up to 255 characters long, but typically is much shorter.
- **Clearing the Error Queue:** An error number/message is removed from the queue each time the SYSTEM:ERRor? command is sent. The errors are cleared first-in, first-out. When the queue is empty, each following SYSTEM:ERRor? query returns +0, "No error". To clear all error numbers/messages in the queue, execute the *CLS command.
- **Maximum Error Numbers/Messages in the Error Queue:** The queue holds a maximum of 30 error numbers/messages. If the queue overflows, the last error number/message in the queue is replaced by -350, "Too many errors". The least recent error numbers/messages remain in the queue and the most recent are discarded.

Example Reading the Error Queue

SYST:ERR?

Query the error queue.

SYSTEM:VERSion?

SYSTEM:VERSion? returns the version number of D-SCPI driver of the modules.

Example SYST:VER?

Returned value is the version number of D-SCPI driver.

SCPI Command Quick Reference

The following table summarizes the SCPI commands for the HP E2273A/E2274A, the relay modules used in a M-Module carrier.

DIAGnostic	:INTerrupt[:LiNe] <number> :INTerrupt[:LiNe]? :TEST?	Set M-Module interrupt level. Query interrupt level. Do diagnostic test to fix specific error.
DISPlay	:MONitor:CARd <number> :MONitor:CARd? :MONitor[:STATe] ON OFF 1 0 :MONitor[:STATe]?	Selects module to be monitored. Queries the card number. Selects monitor mode. Queries the monitor mode.
[ROUte:]	CLOSe <channel_list> CLOSe? <channel_list> OPeN <channel_list> OPeN? <channel_list>	Closes channel(s). Queries channel(s) closed. Opens channel(s). Queries channel(s) opened.
STATus	:OPeRation:CONDition? :OPeRation:ENABle :OPeRation:ENABle? :OPeRation[:EVeNt]? :PRESet	Returns contents of the Operation Condition Register. Enables events in the Operation Event Register to be reported. Returns the mask value set by the :ENABle command. Returns the contents of the Operation Event Register. Sets Enable Register bits to 0.
SYSTem	:ERRor? :VERSion	Returns error number/message in the Error Queue. Returns the version number of D-SCPI driver.

IEEE 488.2 Common Command Reference

The following table lists the IEEE 488.2 Common (*) commands accepted by the HP E2273A/E2274A M-Modules. For more information on Common commands, refer to the user's manual for your HP E1400/E1401 Mainframe, or the ANSI/IEEE Standard 488.2-1987.

Command	Command Description
*CLS	Clears all status registers (see STATus:OPERation[:EVENT]?) and clears the error queue.
*ESE<mask>	Enable Standard Event.
*ESE?	Enable Standard Event Query.
*ESR?	Standard Event Register Query.
*IDN?	Instrument ID Query; returns identification string of the module.
*OPC	Operation Complete.
*OPC?	Operation Complete Query.
*RCL<n>	Recalls the instrument state saved by *SAV.
*RST	Resets the module. Opens all channels.
*SAV<n>	Stores the instrument state.
*SRE<mask>	Service request enable, enables status register bits.
*SRE?	Service request enable query.
*STB?	Read status byte query.
*TST?	Self-test. Executes an internal self-test and returns the first error encountered. Does not return multiple errors. The following is a list of responses you can obtain where "cc" is the card number with the leading zero deleted. +0 if self test passes. +01 self-test failed.
*WAI	Wait to Complete.

Chapter 4

Register Descriptions

About This Chapter

This chapter describes how to program the HP E2273A or E2274A at the register level. Register programming is recommended only if you cannot use the D-SCPI or *VXIplug&play* driver. Chapter contents include:

- Register Addressing Page 39
- Register Descriptions Page 43

Register Addressing

Register Addresses for register-based devices are located in the upper 25% of VXI A16 address space. Every VXI device (up to 256 devices) is allocated a 32-word (64-byte) block of addresses.

The HP E2273A/E2274A M-Modules are register based devices each having two memory windows. One is the same as any other VXIbus register based device (in the A16 address space), all the configuration registers are stored in this area. The other window contains the I/O registers and is located in the A24 address space.

A16 Address Base

In the A16 address space, when reading from or writing to a VXIbus instrument register, a hexadecimal or decimal register address is specified. This address consists of a base address plus a register offset.

The base address used in register-based programming depends on whether the A16 address space is outside or inside the HP E1406A Command Module.

A16 Address Space Outside the Command Module

When the HP E1406A Command Module is not part of the VXIbus system, the module's base address is computed as (see "Register within A16 Address Space" on page 40):

$$C000_h + (LADDR * 64)_h \text{ or } 49,152_{10} + (LADDR * 64)_{10}$$

where $C000_h$ (49,152) is the starting location of the register addresses, LADDR is the M-Module's logical address, and 64 is the number of address bytes per VXI device. For example, if one M-Module's logical address is 120 (78_h), the module's register will have a base address of:

$$C000_h + (120 * 64)_h = \mathbf{DE00_h} \text{ or}$$

$$49,152_{10} + (120 * 64)_{10} = 49,152_{10} + 7680_{10} = \mathbf{56,832_{10}}$$

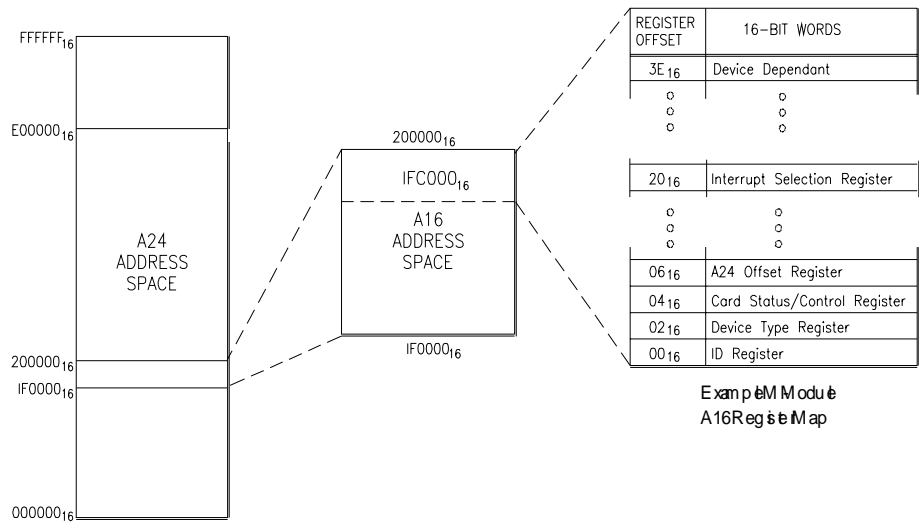

Figure 4-1. Register within A16 Address Space

A16 Address Space Inside the Command Module or Mainframe

When the A16 address space is inside the HP E1406A Command Module (see “Registers within the HP E1406 A16 Address Space” on page 40), the M-module’s base address is computed as:

$$1FC000_h + (120 * 64)_h \text{ or } 2,080,768 + (LADDR * 64)$$

where 1FC000_h (2,080,768) is the starting location of the VXI A16 address space, LADDR is the M-Module’s logical address, and 64 is the number of address bytes per register-based device. Again, the M-Module’s logical address is 120, then the M-Module will have a base register address of:

$$1FC000_h + (120 * 64)_h = 1FDE00_h$$

or (decimal)

$$2,080,768_{10} + (120 * 64)_{10} = 2,080,768_{10} + 7,680_{10} = 2,080,768_{10}$$

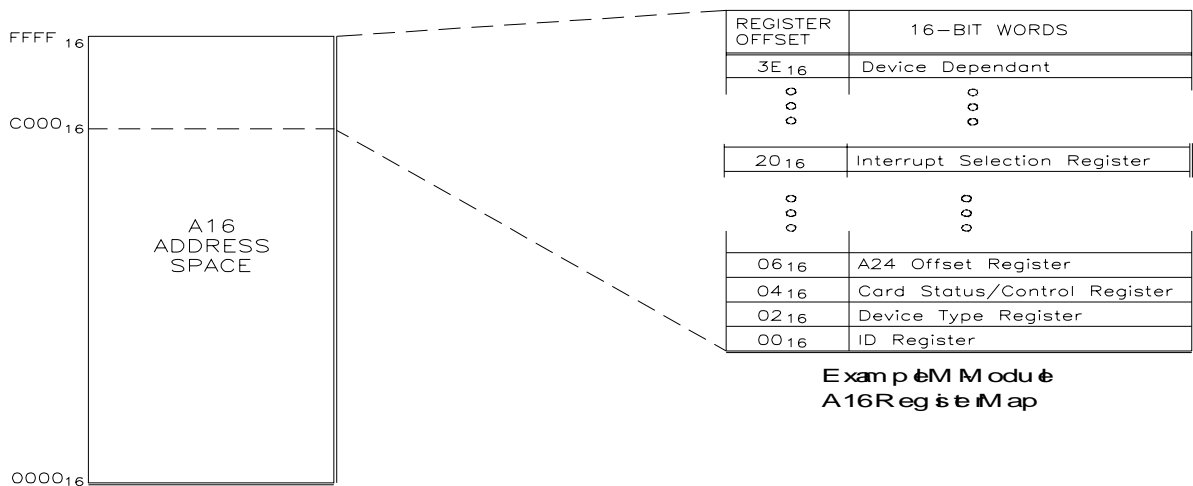

Figure 4-2. Registers within the HP E1406 A16 Address Space

A16 Addressing

The register address in A16 address space equals the Base Address plus the register offset. For example, the HP E2273/E2274A's Offset Register has an offset of 06_h. To access this register, add the offset to the base address to form the register address:

$$DE00_h + 06_h = \mathbf{DE06_h}$$

$$1FDE00_h + 06_h = \mathbf{1FDE06_h}$$

or (decimal)

$$56,832 + 06 = \mathbf{56,838}$$

$$2,088,448 + 06 = \mathbf{2,088,454}$$

For the HP E2273A/2274A, there are five registers in the A16 address space (see "Relay Modules Register Address" on page 42):

- VXI ID Register
- VXI Device Type Register
- VXI Status/Control Register
- VXI Offset Register
- M-Module's Interrupt Control Register

A24 Addressing

When the VXIbus system is powered on, the resource manager determines which area is available for M-Module in the A24 address space. The resource manager will then write the highest 16 bits of the starting address to the Offset Register in A16 address space. The M-Module's register address in A24 address space is determined by combining the value of the Offset Register (as the highest 16 bits) and the register offset (as the lowest 8 bits) of the M-Module (See "Relay Modules Register Address" on page 42.)

For example, the offset of the Relay Register is 14_h, and, if the value in the Offset Register is 2001_h, then the Relay Register's address in A24 address space is:

$$200100_h + 14_h = \mathbf{200114_h}$$

or (decimal)

$$2,097,408_{10} + 20_{10} = \mathbf{2,097,428_{10}}$$

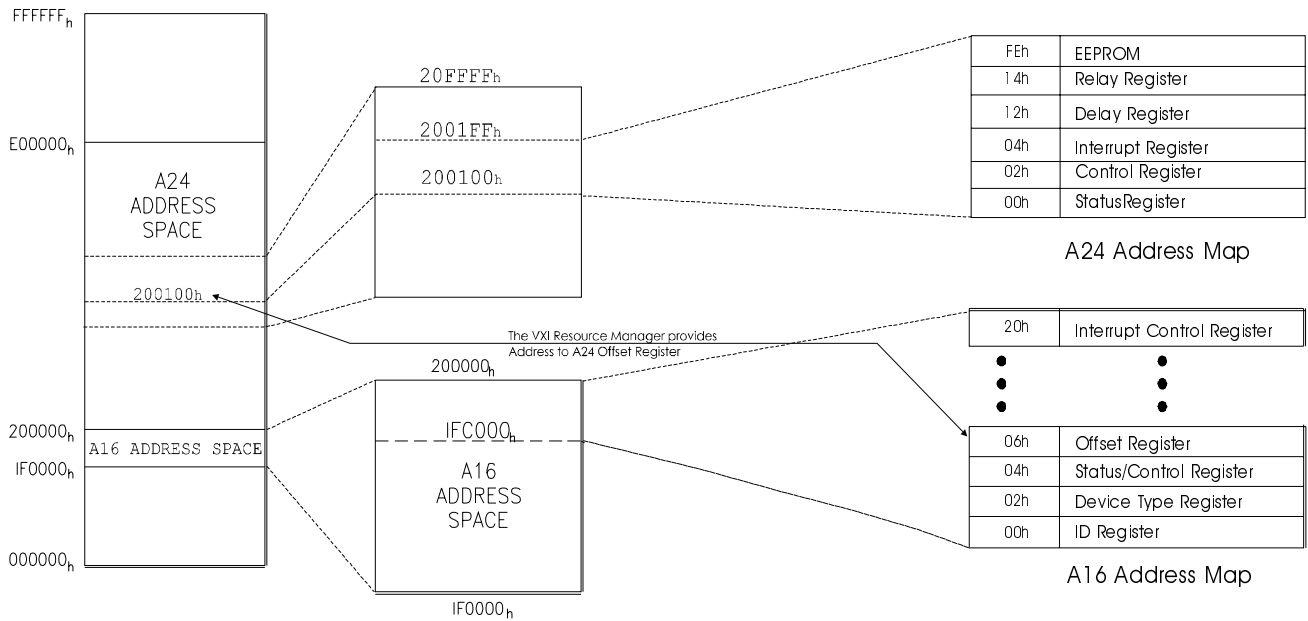

$$* \text{Base Address} = 1FC000_{16} + (\text{Logical Address} * 64)_{16} \text{ or}$$

$$= 2,080,768_{10} + (\text{Logical Address} * 64)_{10}$$

$$\text{A16 Register Address} = \text{Base Address} + \text{Register Offset}$$

For M-Modules, the Register Address is Computed as:

$$\text{Base Address} = \text{Value in Offset Register}$$

$$\text{Register Address} = \text{Base Address} + \text{Register Offset}$$

(A24 address space)

For Example, in above case, the Relay Register Address is:

$$\text{Relay Register Address} = 200100_{16} + 14_{16} = 200114_{16} \text{ or}$$

$$= 2,097,408_{10} + 20_{10} = 2,907,428_{10}$$

Figure 4-3. Relay Modules Register Address

Program Example

The following C language program can be used with any of the Switch M-Modules and demonstrates how to program at the register level. The program closes channels 01 and 03 by writing a logic "1" to bits 0 and 3 in the Relay Register (address = base + 14_h). This program will work on either an HP E2273 or E2274. This program was written and tested in Microsoft Visual C++ but should compile with any standard ANSI C compiler.

To run this program you must have the HP SICL Library, the HP VISA Library, an HP-IB interface module installed in your PC, and an HP E1406 Command Module.

```
#include <visa.h>
#include <stdio.h>
#include <stdlib.h>

ViSession defaultRM,m_mod;
void err_handler();

void main(void)
{
    /*ID & device type registers*/
    unsigned short id_reg, dt_reg;

    /* create and open a device session */
    ViStatus err;
    viOpenDefaultRM (&defaultRM);
    /* Command Module is GPIB-VXI0, M-Module logical address 16 */
    err = viOpen (defaultRM,"GPIB-VXI0::16",VI_NULL,VI_NULL,&m_mod);
    if(err < VI_SUCCESS)
    {
        printf("Unable to open session ");
        return;
    }
    /* read and print the M-Module's ID and Device Type Registers */
    err = viIn16(m_mod,VI_A16_SPACE,0x00,&id_reg);
    if (err < VI_SUCCESS) err_handler(m_mod,err);

    err = viIn16(m_mod,VI_A16_SPACE,0x02,&dt_reg);
    if (err < VI_SUCCESS) err_handler(m_mod,err);

    printf("ID register = 0x%4X\n", id_reg);
    printf("Device Type register = 0x%4X\n", dt_reg);

    /*Close Channels 01 and 03*/
    err = viOut16(m_mod,VI_A24_SPACE,0x14,0xA);
    if (err < VI_SUCCESS) err_handler(m_mod,err);
}
```

(Program Continued on Following Page)

```
/*Close Session */
viClose (m_mod);
viClose (defaultRM);
}
void err_handler ()
/* Error Handling Routine */
{
ViStatus err;
char err_msg[1024] = {0};
viStatusDesc(m_mod,err,err_msg);
if (strcmp ("VI_SUCCESS: No error",err_msg) != 0)
printf("ERROR = %s\n",err_msg);
return;
}
/* End of Error Handling Routine */
```

Register Descriptions

This section describes the HP E2273A/E2274A registers.

Registers in A16 Address Space

The five registers including the VXI ID Register, VXI Device Type Register, Status/Control Register, Offset Register and Interrupt Control Register are mapped in A16 address space (Table 4-1).

Table 4-1. VXIbus Instrument Registers

Address Mapping	Registers
20 _h	M-Module Interrupt Control Register
06 _h	VXI Offset Register
04 _h	VXI Status/Control Register
02 _h	VXI Device Type Register
00 _h	VXI ID Register

ID Register This register contains the M-Module's Device Class, Address Space, and Manufacturer ID.

Table 4-2. VXI ID Register (Base + 00_h)

Bit#	15 - 14	13 - 12	11 - 0
Contents	Device Class	Address Space	Manufacturer ID

- Device Class = 11: Register Based Instrument
- Address Space = 00: A16/A24
- MFG ID = 4095: HP
- A read of the entire register returns CFFF_h.

VXI Device Type Register This register contains the M-Module's required memory and model code.

Table 4-3. VXI Device Type Register (Base + 02_h)

Bit#	15 - 12	11 - 0
Contents	Required Memory	Model Code

- Required Memory = 15: number of 256-byte block required
- Model Code = 025E_h for HP E2273A, 025F_h for HP E2274A
- A read of the entire register returns F25E_h (HP E2273A) or F25F_h (HP E2274A).

Status/Control Register When reading from this register, it is a Status Register with the bit definitions listed in Table 4-4:

Table 4-4. Status Register Bit Definition (Read/Write) Base + 04_h

Bit#	15	14	13 - 4	3	2	1 - 0
Contents	A24/A32 Active	MODID*	Device Dependent	Ready	Passed	Device Dependent

- A24/A32 Active: 1 - A24/A32 registers accessible, Default = 1;
- MODID*: 1 - Device is not selected via the P2 MODID line, 0 - Device is selected via the P2 MODID line;
- Ready: 1 - Device is ready to accept full set of operational commands, 0 - Device is not ready to accept the commands;
- Passed: 1 - Self Test Passed, 0 - Self Test is either failed or executing;

When writing to this register, it is a Control Register with the following bit definitions:

Table 4-5. Control Register Bit Definition (Read/Write) Base + 04_h

Bit #	15	14 - 2	1	0
Contents	A24/A32 Enable	Device Dependent	Sysfail Inhibit	Reset

- A24/A32 Enable: 1 - A24/A32 register accessible, 0 - A24/A32 registers not accessible;
- Sysfail Inhibit: 1 - Stop driving the SYSFAIL* line, 0 - Drive the SYSFAIL* line;
- Reset: 1 - Reset the device.

Offset Register This register contains the value of the base address necessary to access the M-Module's A24 address space. This register's content is determined automatically by the Command Module.

Table 4-6. Offset Register Bits Definition (Read/Write) Base + 06_h

Bit#	15 - 0
Contents	Determined Automatically by the Command Module

M-Module Interrupt Control Register This register specifies which interrupt line the M-Module will use. HP Command Modules service interrupt line 1 by default, so normally you do

not need to change the interrupt line

Table 4-7. M-Module Interrupt Control Register (Base + 20_h)

Bit#	15 - 3	3	2	1	0
Contents	reserved	INTC	Interrupt Level		

- INTC: 1 - Support Interrupt C;
0 - Support Interrupt A or B or no interrupt
Default = 1
- Interrupt Level: Level 0 disable the interrupt
Default = Interrupt 1
- Interrupt level selections are listed in Table 4-7:

Table 4-8. Interrupt Level Selection

Bit 2 1 0	Interrupt Level
000	Disable Interrupt
001	IRQ1
010	IRQ2
011	IRQ3
100	IRQ4
101	IRQ5
110	IRQ6
111	IRQ7

Registers in A24 Address Space

There are five registers in A24 address space on both HP E2273/74A. Table 4-9 lists the address mapping:

Table 4-9. HP E2273/E2274A Registers

Address Mapping	Registers
FE _h	EEPROM
(16-FD _h)	(Reserved)
14 _h	Relay Register
(06-12 _h)	(Reserved)
04 _h	Interrupt Register
02 _h	Control Register
00 _h	Status Register

Status Register

Table 4-10. Status Register (Read Only) Base + 00_h

Bit#	15 - 8	7	6 - 1	0
Contents	Reserved	BUSY*	Reserved	RIRQX

- BUSY*: 0-Relay is busy (not stable yet).
- RIRQX: 1-Relay interrupt.
- The BUSY bit will be being “0” for 13 ms for HP E2273A and 16 ms for HP E2274A after the Relay Register is written.
- This BUSY* bit is re-triggerable.

Control Register

Table 4-11. Control Register (Read/Write) Base + 02_h

Bit #	15 - 5	1	0
Contents	Reserved	RENABLE	Soft Reset

- RENABLE: 1 - Enable relay interrupt (After BUSY timer).
- Soft Reset: 1 - Soft Reset the M-Module.

When power-on or reset, all bits of Control Register are set to zero.

Interrupt Register

Table 4-12. Interrupt Register (Read Only) Base + 04_h

Bit #	15 - 1	0
Contents	Reserved	RIRQX

- RIRQX: Relay interrupt

Relay Register

Table 4-13. HP E2273A Relay Register (Read/Write) Base + 14_h

Bit #	15 - 8	7	6	5	4	3	2	1	0
Contents	Reserved	Chan 7	Chan 6	Chan 5	Chan 4	Chan 3	Chan 2	Chan 1	Chan 0

- 0 = channel open, 1 = channel closed.

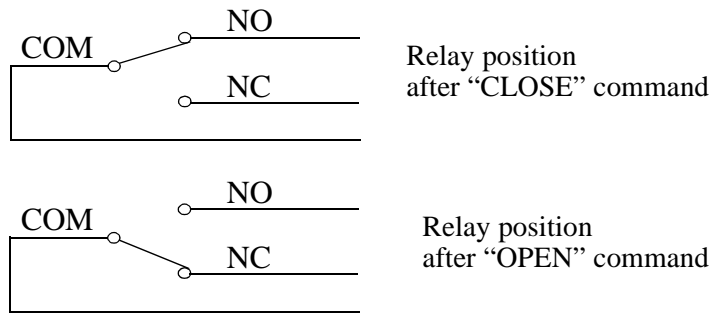

Figure 4-4. Write a "1" or "0" to the Register Bit to Close/Open the Relay

Table 4-14. HP E2274A Relay Register (Read/Write) Base + 14_h

Bit #	15 - 4	3	2	1	0
Contents	Reserved	Chan 3	Chan 2	Chan 1	Chan 0

- 0 = channel open, 1 = channel closed.

EEPROM The ID EEPROM contains sixty-four 16-bit words of M-Module ID data and VXI M-Module data.

Note It is much easier to read the module ID data from the VXI registers (A16 memory area) instead of reading the ID EEPROM Register. A16 addressing is discussed earlier in this chapter.

Table 4-15. ID EEPROM Contents

Word#	Description	Value
0	Sync code	5346 _h
1	module number (binary code)	0689 _h (E2273A's Module Number) 068A _h (E2274A's Module Number)
2	revision number (binary code)	
3	module characteristics	1868 _h (According to M-Module Specification)
4 - 7	reserved	
8 - 15	User-defined	
16	VXI Sync code	ACBA _h (2's complement of 0x5346)
17	VXI-ID	CFFF _h (According to VXI Specification)
18	VXI-Device Type	F25E _h (E2273's Module Code) F25F _h (E2274's Module Code)
19 - 31	Reserved	
32 - 63	User-defined	

The module characteristic words are defined below:

- D15 = 0: no burst access;
- D14 -D13: reserved
- D12 = 1: module need +/- 12V;
- D11 = 1: module need +/- 5V;
- D10 = 0: module without trigger output;
- D09 = 0: module without trigger input;
- D08-D07 = 00: no DMA requester;
- D06-D05 = 11: interrupt method C(INTC);
- D04-D03 = 01: 16-bit data bus(D16);
- D02-D01 = 00: 8-bit address bus(A08);
- D00 = 00: M-module does not support memory access.

M-Module Specification Compliance

The HP E2273 and E2274 M-Modules comply with the Mezzanine M-Module Specification.

HP E2273A 8-Channel Form C Switch M-Module Specifications

Caution The following voltage limits designated “Cleanroom Environment” apply only if the product is installed in a humidity-controlled (<60% RH) environment where airborne contaminants and transients are controlled, and there is NOT a relay connection made to power mains. If these conditions CANNOT be maintained, then the maximum voltage is 60 VDC, 43 VAC-rms or 68 VAC-peak.

Maximum Voltage--Cleanroom Environment (any terminal to any other terminal)

- 200 VDC
- 141 VAC rms
- 200 VAC peak

Maximum Voltage--Non-Cleanroom Environment (any terminal to any other terminal)

- 60 VDC
- 43 VAC rms
- 68 VAC peak

Maximum Current (non-inductive)

- Per Switch: 1 ADC, 0.707 AAC rms, 1 AAC peak

Maximum Power

- Per Switch: 40 W DC, 40 VA AC
- Per Module: 100 W DC, 100 VA AC

HP E2273A Specifications (continued)

Maximum Thermal Offset

- < 20 μ V (typical)

Closed Channel Resistance

- End of Life: < 3.5 Ω

Insulation Resistance (between any two points)

- $\leq 40^{\circ}\text{C}$, $\leq 65\%$ RH: $10^7 \Omega$ (typical)
- $\leq 25^{\circ}\text{C}$, $\leq 40\%$ RH: $10^7 \Omega$ (typical)

AC Specifications

- Typical Bandwidth (-3dB): 10 MHz
- Crosstalk (dB, channel-to-channel):
 - <10 kHz: <-80 dB
 - <100 kHz: <-70 dB
 - <1 MHz: <-50 dB
- Closed Channel Capacitance:
 - Channel-to-Channel: <30 pF (typical)
 - Channel-to-Common: <40 pF (typical)

General Characteristics

- Typical Relay Life (number of operations)
 - No Load: 5×10^6
 - Rated Load: 1×10^5
 - Time to open or close a channel (register programming): 13 msec

Connector Type

- 44-pin D-Sub

Power Up/Down States

Non-latching relays (all relays open at power up/down).

HP E2274A 4-Channel Form C Power Relay M-Module Specifications

Caution The following voltage limits designated “Cleanroom Environment” apply only if the product is installed in a humidity-controlled (<60% RH) environment where airborne contaminants and transients are controlled, and there is NOT a relay connection made to power mains. If these conditions CANNOT be maintained, then the maximum voltage is 60 VDC, 43 VAC-rms or 68 VAC-peak.

Maximum Voltage--Cleanroom Environment (any terminal to any other terminal)

- 125 VDC
- 141 VAC rms
- 200 VAC peak

Maximum Voltage--Non-Cleanroom Environment (any terminal to any other terminal)

- 60 VDC
- 43 VAC rms
- 68 VAC peak

Maximum Current (non-inductive)

- Per Switch: 5 ADC, 3.53 AAC rms, 5 AAC peak

Maximum Power

- Per Switch: 100 W DC, 100 VA AC
- Per Module: 300 W DC, 300 VA AC

Maximum Thermal Offset

- < 20 μ V (typical)

Closed Channel Resistance

- End of Life: < 2 Ω

Insulation Resistance (between any two points)

- $\leq 40^{\circ}\text{C}$, $\leq 65\%$ RH: $10^8 \Omega$ (typical)
- $\leq 25^{\circ}\text{C}$, $\leq 40\%$ RH: $10^8 \Omega$ (typical)

HP E2274A Specifications (continued)

AC Specifications

- Typical Bandwidth (-3dB): > 10 MHz
- Crosstalk (dB, channel-to-channel):
 - <100 kHz: <-80 dB
 - <1 MHz: <-60 dB
 - <10 MHz: <-40 dB
- Closed Channel Capacitance:
 - Channel-to-Channel: 25 pF (typical)
 - Channel-to-Common: 60 pF (typical)

General Characteristics

- Typical Relay Life (number of operations)
 - No Load: 5×10^7
 - Rated Load: 3.5×10^4
 - Time to open or close a channel (register programming): 16 msec

Connector Type

- 44-pin D-Sub

Power Up/Down States

Non-latching relays (all relays open at power up/down).

Symbols

*CLS, 37
*ESE, 37
*ESE?, 37
*ESR?, 37
*IDN?, 37
*OPC, 37
*OPC?, 37
*RCL, 37
*RST, 37
*SAV, 37
*SRE, 37
*SRE?, 37
*STB?, 37
*TST?, 37
*WAI, 37

A

A16 address space, 39–41
A24/A32 address space, 39
Abbreviated Commands, 22

B

Base address, 39
Block diagram description, 14

C

Card number, 17
Card number (in channel list), 17
Channel lists, 17
Channel numbers, 17–18
Channel range, specifying, 17
Channels, closing example, 18
Channels, opening and closing, 17
CLOSE, 27
CLOSE?, 28
Closing and opening channels, 17
Closing channels example program, 18
Closing multiple channels example, 18
Command Module, 39–40
Command Quick Reference, 37
Command Separator, 21
Command Types, 21
Commands

abbreviated, 22
IEEE 488.2, 21, 37
implied, 22
linking, 23
optional parameters, 23
parameters, 23
Quick Reference, 36–37
types, 21

Common (*) Command Format, 21

Common (*) Commands, 21, 37

*CLS, 37
*ESE, 37
*ESE?, 37
*ESR?, 37
*IDN?, 37
*OPC, 37
*OPC?, 37
*RCL, 37
*RST, 37
*SAV, 37
*SRE, 37
*SRE?, 37
*STB?, 37
*TST?, 37
*WAI, 37

Compliance, M-Module specification, 51

Configuration registers, 39

D

Decimal, 39
Description, block diagram, 14
Device Type Register, 41
DIAG:INT, 24
DIAG:INT?, 24
DIAGnostic Subsystem, 24
DISPLay Subsystem, 26
DISPLay:MONitor[:STATe], 26
DISPLay:MONitor[:STATe]?, 26

E

Example 1, initial operation, 15
Example 2, closing multiple channels, 18
Example program

- closing multiple channels, 18
- initial operation, 15
- register based, 43

I

- I/O registers, 39
- ID number, 11
- ID string, reading, 15
- Identifying M-Modules, 11
- *IDN? program example, 15
- IEEE 488.2 Common Commands, 21, 37
- Implied Commands, 22
- Initial operation, 15
- Initial operation program example, 15

L

- Linking Commands, 23
- Lists, channel, 17

M

- Mainframe, 40
- Memory windows, 39
- M-Module ID number, 11
- M-Module specification compliance, 51
- Multiple channels, 17
- Multiple channels, closing, 18

N

- Numbers, channel, 17-18

O

- OPEN, 29
- OPEN?, 30
- Opening and closing channels, 17
- Operation, initial, 15
- Optional Parameters, 23

P

- Parameters, 23
 - optional, 23
 - types, 23
- Program example
 - closing channels, 18
 - initial operation, 15
 - register-based, 43
- Programming, SCPI, 15

R

- Register
 - Device Type Register, 41
 - ID Register, 41
- Register Address, 39
- Register address, 41
- Register offset, 39
- Register-based device, 39
- Register-based program example, 43
- ROUTe Subsystem, 27
- ROUTe: Subsystem, 27

S

- SCPI Command Format, 21
- SCPI Command Reference
 - DISPLay:MONitor[:STATe], 26
 - DISPLay:MONitor[:STATe]?, 26
 - STATus:OPERation:CONDition?, 33
 - STATus:OPERation:ENABLE, 33
 - STATus:OPERation:ENABLE?, 33
 - STATus:OPERation[:EVENT]?, 34
 - STATus:PRESet, 34
 - SYSTem:CDEscription?, 35
 - SYSTem:ERRor?, 35
- SCPI Commands, 21
 - abbreviated, 22
 - format, 21
 - implied, 22
 - linking with Common commands, 23
 - optional parameters, 23
 - parameters, 23
 - quick reference, 36
 - reference, 36
- SCPI program example, 15, 18
- SCPI programming, 15
- Self-test, example program, 15
- Single channels, 17
- Specification compliance, M-Module, 51
- Specifications, 51
- STATus Subsystem, 31
- STATus:OPERation:CONDition?, 33
- STATus:OPERation:ENABLE, 33
- STATus:OPERation:ENABLE?, 33
- STATus:OPERation[:EVENT]?, 34
- STATus:PRESet, 34
- Subsystem ROUTe:, 27
- Subsystem, DIAGnostic, 24
- Subsystem, DISPlay, 26
- Subsystem, ROUTe, 27

Subsystem, STATus, [31](#)
Subsystem, SYSTem, [35](#)
Switch module channel numbers, [18](#)
SYSTem Subsystem, [35](#)
SYSTem:CDEscription?, [35](#)
SYSTem:ERRor?, [35](#)

T

*TST? program example, [15](#)

